



Rewarding Learning

ADVANCED
General Certificate of Education
2025

Centre Number

--	--	--	--	--

Candidate Number

--	--	--	--	--

Physics

Assessment Unit A2 3B

assessing

Practical Techniques
and Data Analysis



[APH32]

APH32

MONDAY 16 JUNE, MORNING

TIME

1 hour.

INSTRUCTIONS TO CANDIDATES

Write your Centre Number and Candidate Number in the spaces provided at the top of this page.

You must answer the questions in the spaces provided.

Do not write outside the boxed area on each page or on blank pages.

Complete in black ink and use a dark HB pencil for drawings and graphs.

Do not write with a gel pen.

Answer **all five** questions.

INFORMATION FOR CANDIDATES

The total mark for this paper is 50.

Figures in brackets printed down the right-hand side of pages indicate the marks awarded to each question or part question.

You may use a scientific calculator.

14733



16APH3201

- 1 **Fig. 1.1** shows a trace on an oscilloscope screen when a signal of frequency 250 Hz and peak voltage of 1 V is displayed.

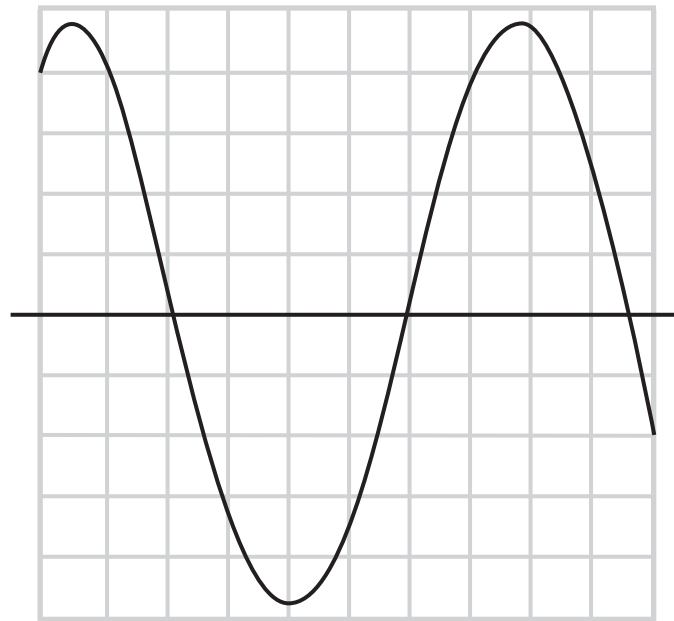

Fig. 1.1



The timebase setting is changed to 1 ms cm^{-1} and the volts per division scale is changed to 0.5 V cm^{-1} .

- (a) On **Fig. 1.2**, draw the trace as it now appears on the screen. Use the space above **Fig. 1.2** to show any working out.

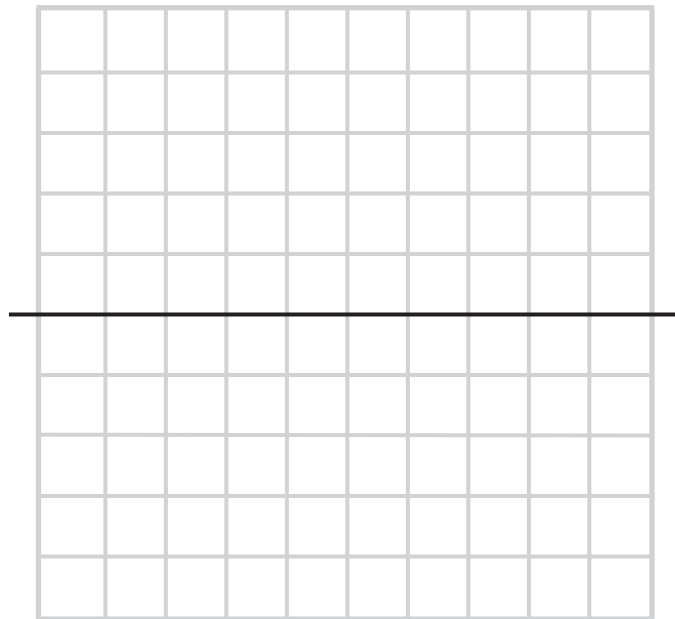

Fig. 1.2

[4]

- (b) Describe what would be seen on the oscilloscope screen if the timebase was turned off.

[2]

[Turn over



BLANK PAGE
DO NOT WRITE ON THIS PAGE

14733



16APH3204



- 2 In an experiment to determine the density of air, the mass of a flask of air was measured, as shown in **Fig. 2.1**.

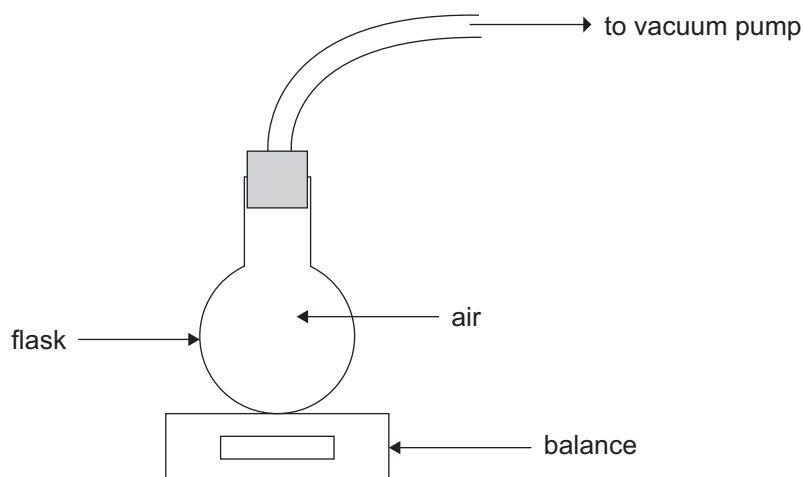

Fig. 2.1

A vacuum pump was used to remove the air from the flask and the mass of the empty flask was measured. The readings on the balance were recorded in **Table 2.1**.

Table 2.1

Reading on balance before air removed / g	Reading on balance after air removed / g
765.60	763.35

- (a) (i) Calculate the mass of air in the flask. State the uncertainty in the value you have calculated.

Mass of air in the flask = _____ \pm _____ g [2]

- (ii) Describe the steps that should be taken to improve the reliability of this value.

_____ [2]

[Turn over



(b) The volume of the flask was found to be 1860 cm^3 .

(i) Describe how the volume of the flask could have been measured using a 2000 cm^3 measuring cylinder.

[2]

(ii) The top part of the measuring cylinder is shown in **Fig. 2.2**. State the uncertainty in the scale of the measuring cylinder.

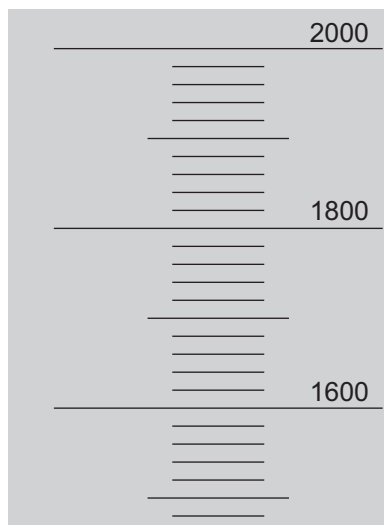

Fig. 2.2

Uncertainty = \pm _____ cm^3

[1]



(c) (i) Calculate the density of the air in g cm^{-3} .

Give your answer to the appropriate number of significant figures.

Density = _____ g cm^{-3} [3]

(ii) Calculate the absolute uncertainty in the value for the density of air calculated in (c)(i).

Uncertainty = \pm _____ g cm^{-3} [4]

[Turn over

14733



16APH3207

- 3 (a) A non-SI unit for density is slug ft⁻³ where 1 slug = 14.59 kg and 1 m = 3.281 ft. The density of water is 1.940 slug ft⁻³. Determine the density of water in kg m⁻³.

Give your answer to the appropriate number of significant figures.

You must clearly show each step in your working out to be awarded marks in this question.

Density of water = _____ kg m⁻³ [3]



(b) Capillary action causes a liquid to rise up a tube to a height h above the water level, as shown in **Fig. 3.1**.

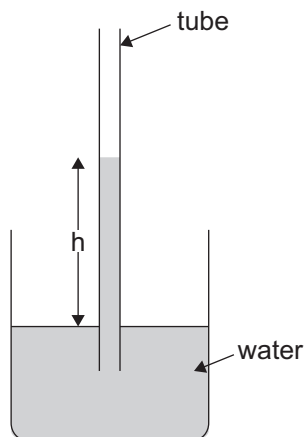

Fig. 3.1

For water, a simplified version of the relationship between the height h and the radius r of the tube is given by **Equation 3.1**

$$h = \frac{2T}{r\rho g} \qquad \text{Equation 3.1}$$

where

T is the surface tension of water,

ρ is the density of water, and

g is the acceleration of freefall, 9.81 m s^{-2} .



An experiment was carried out to test **Equation 3.1** using tubes of different radii.

The grid of **Fig. 3.2** shows a graph of h against $1/r$.

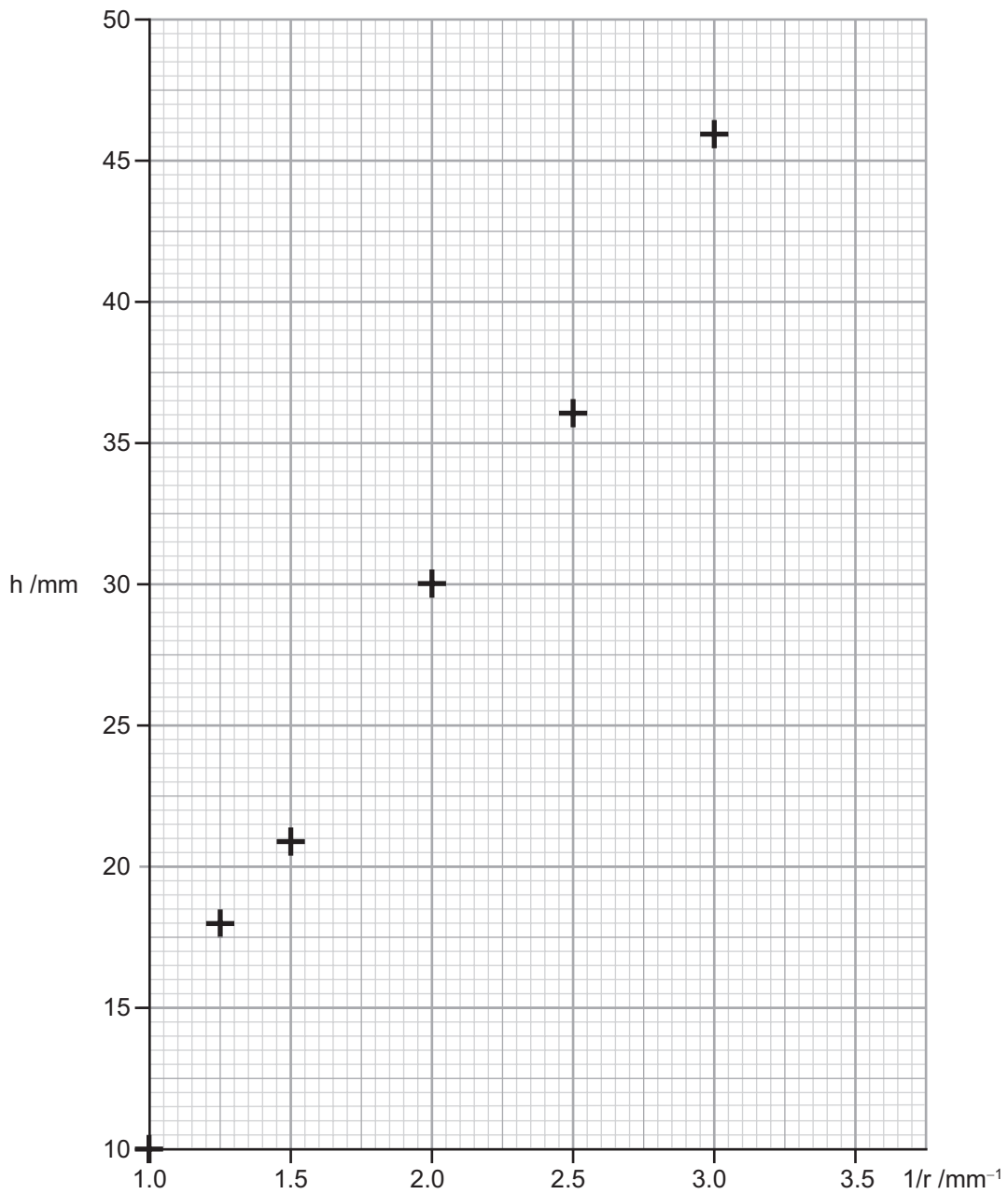

Fig. 3.2

Two more points are to be plotted on the graph in **Fig. 3.2** from tubes of diameter d as shown in **Table 3.1**.



Table 3.1

d /mm	h /mm	1/r /mm ⁻¹
1.14	25	
0.74	42	

- (i) Complete the third column of **Table 3.1** and use the values to plot two more points on the grid of **Fig. 3.2**. Then draw a best fit line for the plotted points.

[4]

- (ii) Calculate the gradient of the graph. Give your answer in m².

Gradient = _____ m²

[4]

- (iii) Use your answer to (a) and (b)(ii) to calculate the surface tension T.

T = _____ kg s⁻²

[3]

[Turn over



- 4 Joule's law describes the relationship between the heat Q produced in a coil of wire and the current I flowing through the wire. Joule's law is represented by **Equation 4.1**.

$$Q = I^2Rt \quad \text{Equation 4.1}$$

where R is the resistance of the coil of wire and t is the time for which the current flows.

In an experiment to verify Joule's law, a heating coil was placed in a fixed mass of water as shown in **Fig. 4.1**. A current was allowed to flow through the coil for a fixed time and the rise in temperature of the water was recorded. The resistance of the coil was constant.

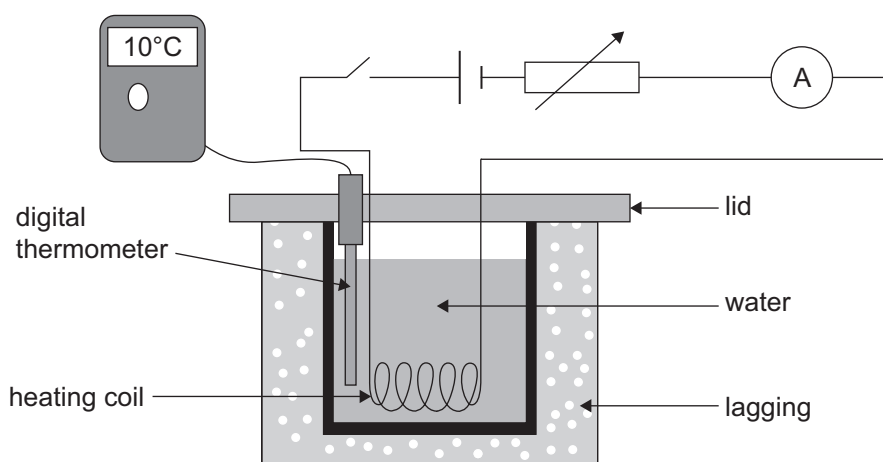

Fig. 4.1

- (a) (i) **Equation 4.2** appears on the data and formulae sheet.

$$Q = mc\Delta\theta \quad \text{Equation 4.2}$$

Use **Equation 4.2** to explain why a measurement of the change in temperature $\Delta\theta$ can be used, instead of a measurement of Q , to investigate Joule's law.

[2]



- (ii) Describe one addition to the apparatus that would improve the accuracy of the experiment and explain how it would help.

[2]

- (b) (i) The experiment was repeated for different values of I .

Use **Equation 4.1** and **Equation 4.2** to show that a graph of $\text{Log } \Delta\theta$ against $\text{Log } I$ will be a straight line graph.

[3]

- (ii) How can Joule's law be verified from the gradient of the graph?

[1]

[Turn over



- 5 Moseley's law gives the relationship between the frequency f of the X-ray emitted by an atom and the atomic number Z of the atom.

Moseley's law is represented by **Equation 5.1**

$$\sqrt{f} = p(Z - q) \quad \text{Equation 5.1}$$

where p and q are constants.

Fig. 5.1 shows a graph of Z against \sqrt{f} .

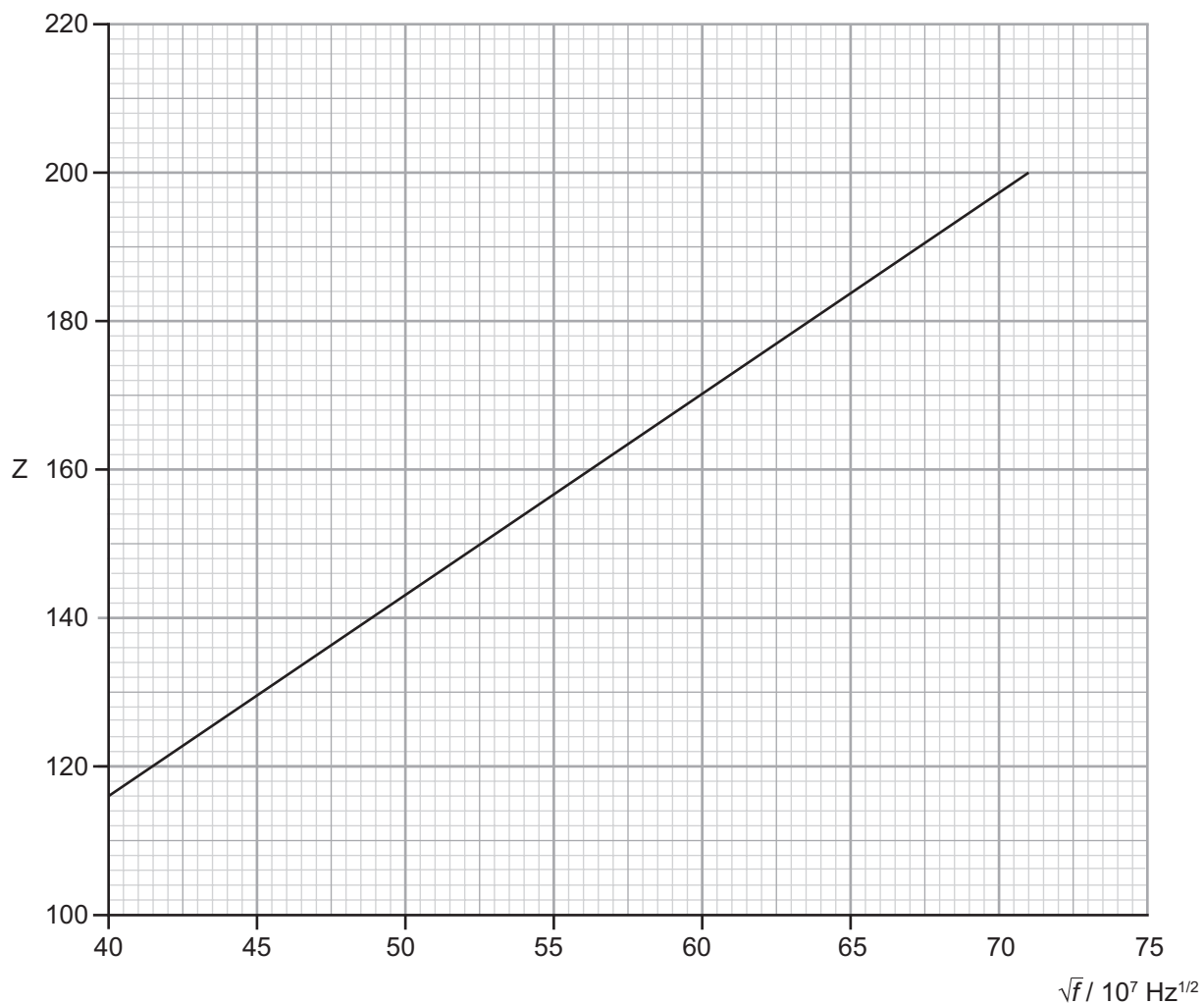

Fig. 5.1



The magnitude of the gradient of the graph is 2.7×10^{-7} .

(a) Calculate the y-intercept of the graph in **Fig. 5.1**.

y-intercept = _____

[3]

(b) Use the graph in **Fig. 5.1** and your answer to (a) to calculate values for the constants p and q in **Equation 5.1**. Give the unit of the constants. If there is no unit write 'No Unit'.

p = _____

Unit of p = _____

q = _____

Unit of q = _____

[5]



DO NOT WRITE ON THIS PAGE

THIS IS THE END OF THE QUESTION PAPER

For Examiner's use only	
Question Number	Marks
1	
2	
3	
4	
5	

Total Marks	
--------------------	--

Examiner Number

Permission to reproduce all copyright material has been applied for.
In some cases, efforts to contact copyright holders may have been unsuccessful and CCEA will be happy to rectify any omissions of acknowledgement in future if notified.

APH32/6
299932



16APH3216